

Sludge Degritting Removes Grit Entrained in Sludge

SlurryCup / Grit Snail Provides the Ideal Solution in this Difficult Application

Wastewater Application Sheet

Product Highlights

- Highly efficient over a wide range of flows
- Designed for peak grit load (PWWF)
- All stainless steel design
- Small footprint
- Low operating costs
- Low maintenance

System Highlights

Equipment

- SlurryCup™
- Grit Snail®

Process Parameters

- 75 micron (μm) removal
- 90% + total capture efficiency
- <20% VS (organic content)
- >60% TS final dewatered grit

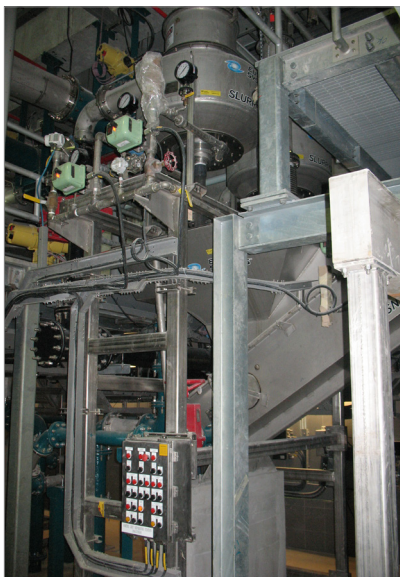

Sludge Degritting System

Overview

Historically, grit removal facilities have been located in the headworks of a plant. However, many have under performing grit removal systems that are unable to remove grit loads that enter their plants. For this reason, large amounts of grit can pass through the headworks, settle in the clarifiers, and negatively impact the sludge processing equipment and processes. As a result, it becomes necessary to de-grit the clarifier sludge before processing and disposal. A SlurryCup™ / Grit Snail® grit washing and dewatering system can be used to effectively de-grit sludge, reducing abrasive wear of sludge processing equipment and improving sludge digestion processes.

As part of the process that interacts with grit, sludge degritting protects clarifier rake arms, sludge transfer pumps (primary, thickened, digested, WAS, RAS), centrifuges and other expensive mechanical equipment by reducing unnecessary abrasive wear. Furthermore, removing grit that would otherwise deposit in digesters or other digestion processes allows these processes to operate more efficiently. Grit build-ups in digesters can create unstable operating conditions by increasing foaming, reducing volatile solids destruction, impairing mixing and reducing gas production. Removing these deposits is very expensive, dangerous and time-consuming, requiring taking the digesters offline, exposure to toxic gasses, confined space entry, repairs and re-commissioning, not to mention removing, handling and disposing of the deposited material.

SlurryCup™ / Grit Snail®

The SlurryCup™ provides high performance sludge degritting; removing grit and fine abrasives as small as 75 μm (and larger), with minimal organic solids (VS). The SlurryCup™'s open free-vortex operates as a centrifugal solids separator and classifier with secondary washing. The liquid-particle separation occurs within the SlurryCup™ as a result of centrifugal forces exceeding fluid drag forces. Classification and separation of particles occurs within the boundary layer, which retains fine grit particles while organics are sent to digestion. Once the grit particles are captured in the boundary layer and swept to the center, the hydraulic valve uses rinse water for secondary washing to produce a clean product with low VS. This allows the SlurryCup™ to remove and wash over 90% of 75 μm grit and larger in both headwork and sludge degritting applications.

The Grit Snail® captures fine grit and abrasives by providing sufficient clarifier area to retain 75 μm particles. A slow moving 1-2 ft/min. (30-60 cm/min.), cleated belt gently lifts grit from the clarifier pool without re-suspending captured fine grit particles, which would allow them to escape with the clarifier overflow. The combined SlurryCup™ and Grit Snail® sludge degritting system delivers clean, dry grit containing 60% total solids and less than 20% volatile solids (organics).



Conventional Sludge Degritting

Conventional sludge degritting systems typically incorporate cyclone concentrators and grit classifiers. The outlet apex valves required on cyclone concentrators restrict the amount of grit they can process and are subject to plugging as grit loads increase, particularly during wet weather. During wet weather events plants can see 20 or 30 times the grit volume and receive as much as 70% of their annual grit load. Typical classifiers have small clarifier tanks with high overflow rates and fast turning turbulent screws for washing and transporting grit. Both of these features reduce the size and amount of grit that can be retained. Side-by-side testing shows that the SlurryCup™ grit washing technology removes as much as 20 times the grit volume removed by cyclone/screw classifier systems. The organic content of the grit output from cyclone/screw classifiers typically exceeds 35% which significantly increases odor issues and the volume of materials to send to landfill.

Advantages

- Over 90% removal of 75 µm particles (2.65 Specific Gravity)
- Increased efficiency at higher flows which carry higher grit loads
- Removes as much as 20 times more grit than a cyclone / screw classifier
- First flush solids handling capacity minimizes grit loss
- Low organic content (< 20% VS) of classified grit, reduces volume going to disposal
- 60% total solids content
- Enclosed system improves odor control
- Significantly reduces O&M costs
- Hydro International sludge degritting is a proven, tested technology with a long history of operation

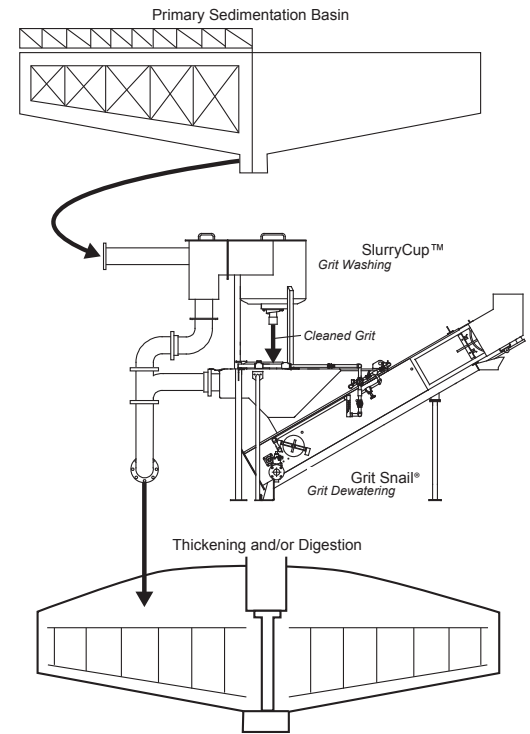

*SlurryCup™ / Grit Snail®
Sludge Degritting Application*



North Shore Sanitary District Clean Grit Output



Confidential Plant - Florida