

Hydro GritCleanse™

Fluidized Bed Grit Washing & Dewatering

Product Summary

Cut landfill costs and reduce odor issues with cleaner, drier grit.

Hydro GritCleanse™ fluidized bed grit washing significantly reduces volatile solids while retaining 95% of grit ≥ 75 micron. Designed to be paired with Hydro International's industry leading HeadCell® and Grit King® grit separation technologies as well as other conventional grit removal systems to output grit with <5% volatile solids. Hydro GritCleanse™ is complemented by Hydro's expertise in supplying whole system solutions.

Performance & Capacity

- » All Hydro GritCleanse™ systems produce very clean and dry grit with $\leq 5\%$ volatile solids in grit output, & $\geq 90\%$ total solids in grit output under normal operating conditions
- » We offer multiple size systems with different performance levels and capacities to match our clients' needs.

Hydro GritCleanse™ Performance by Clarifier Size		
Clarifier Size	95% removal of $\geq 75 \mu\text{m}$ grit	95% removal $\geq 212 \mu\text{m}$ grit
7' (2.1 m)	150-300 gpm (9.5-18.9 L/s)	300-400 gpm (18.9-25.2 L/s)
10' (3.1 m)	400-600 gpm (25.2-37.9 L/s)	600-800 gpm (37.9-50.5 L/s)

How it Works

Flow is introduced tangentially into the conical clarifier forcing grit to contact the vessel walls creating drag forces and establishing a rotary flow pattern. Incoming grit settles into the low velocity boundary layer at the inside wall of the vessel. The structured, laminar flow pattern allows retention of fine and slowly settling grit particles while the interior baffle prevents short-circuiting. Once in this boundary layer grit is further decelerated and settles to the bottom of the unit into the gently agitated fluidized bed where physical forces separate fixed and volatile solids by density. Grit settles to the bottom of the bed while the lighter organic material carries out with the effluent. Large organics remain in suspension at the top of the bed and are intermittently discharged via an adjacent port on a timed basis. Washing occurs in the fluidized bed as organic material attached to the grit particles is scrubbed away due to friction between particles and the higher density grit descends to the bottom. Washed grit is discharged intermittently based on bed pressure via the dewatering screw.

Hydro GritCleanse™ Flow Path

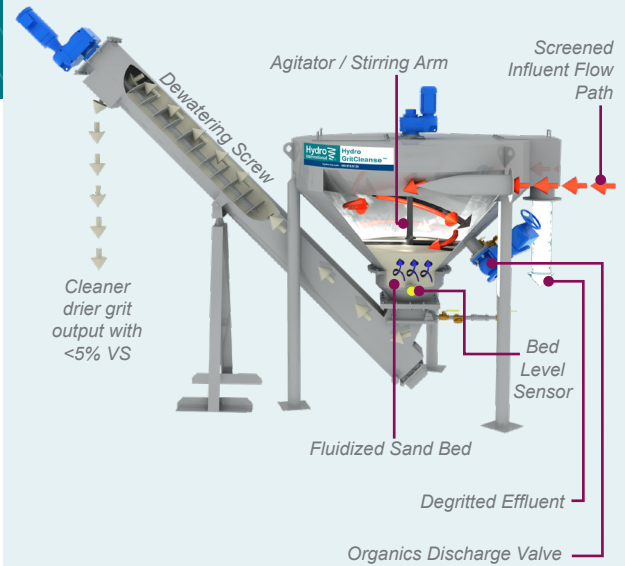

Applications

- » Grit washing where very low volatile solids are required
- » Grit washing / dewatering for new, expanding, and upgrading WWTPs
- » Replacement for worn out or ineffective grit washing and dewatering systems

Benefits

- » Reducing organics reduces volume, hauling, and disposal costs
- » Optimized to work with HeadCell® or Grit King® and provide single supplier accountability and full system guarantee
- » Reduced odor from lower VS and fully enclosed design = happy operators & neighbors
- » Designed for easy maintenance and access



Design Notes

- » All Stainless Steel construction and heavy duty design ensures long product life
- » Shafted screw design reduces wear and eliminates replacement of wear bars or liners
- » System has numerous design features allowing easy maintenance
- » Influent is structured so that boundary layer forces augment the unit's ability to capture fine particles



Operating Hydro GritCleanse™ System



Conventional Grit Washer
Output >50% VS



Hydro GritCleanse™
Output <5% VS

Cleaner, Drier Grit Costs Less to Landfill

With significantly lower organic and water content than other types of grit systems, the Hydro GritCleanse™ saves your plant money!

Field tests have shown final output to contain up to 5X more fixed solids per yd³ of grit vs. other grit washing technologies.

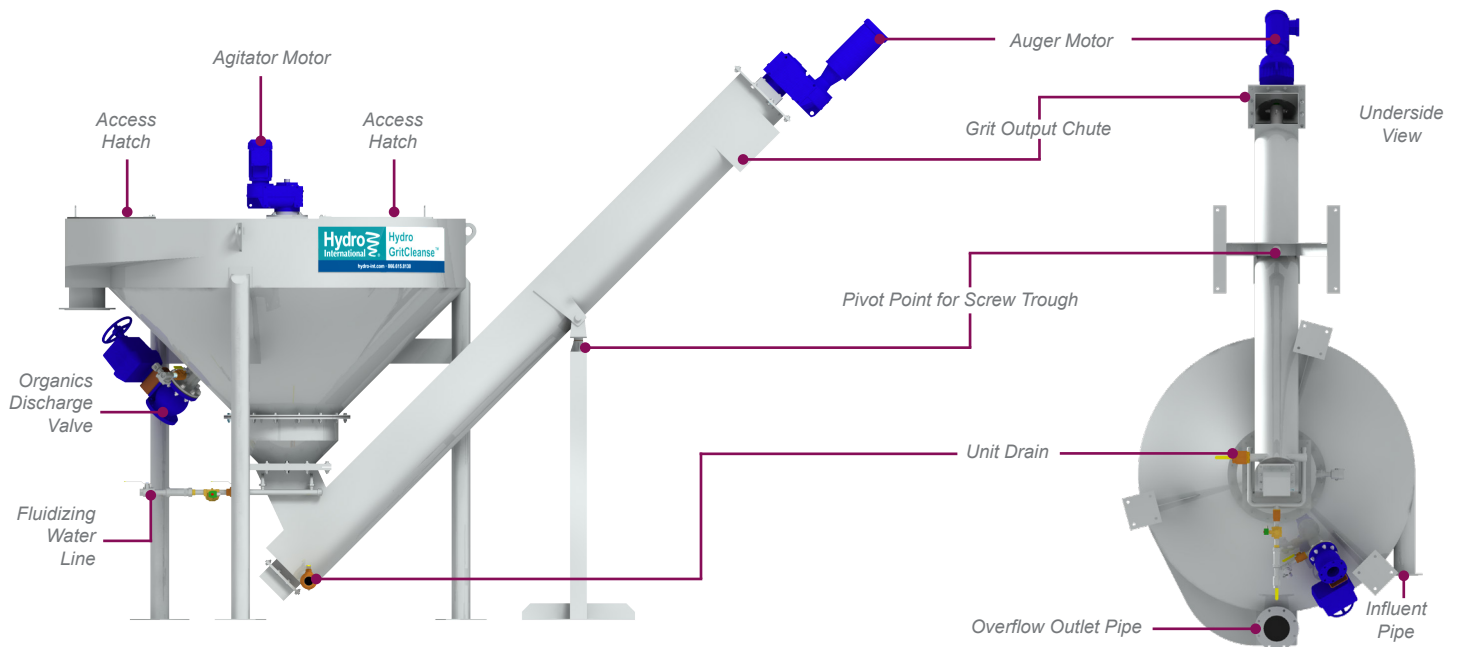

📍 Hydro International
2925 NE Alcock Suite 140 | Hillsboro, OR 97124
☎ Tel: (866) 615-8130
✉ Email: questions@hydro-int.com
🌐 Web: hydro-int.com

Learn more

Visit our website to learn how Hydro GritCleanse™ grit washing & dewatering will protect your plant, reduce your operational costs, and improve the performance of your entire plant.

→ hydro-int.com/GritCleanse