

Hydro-Sludge™ Screen

Remove and compact solids from sludge to reduce solids handling costs and improve downstream treatment efficiency

Product Summary

The Hydro-Sludge™ Screen is a superior sludge screening solution for municipal and industrial applications, delivering solid performance and straightforward maintenance.

Hydro-Sludge™ Screen delivers savings by cutting the costs of solids handling and equipment maintenance.

Applications

Municipal wastewater sludge screening

- » Primary
- » Secondary
- » Imported

Industrial wastewater sludge screening

- » Direct tanker, pumped feed or combination

Maritime sludge screening

- » Ship-board preliminary treatment

Specification

- » Stainless steel components.
- » Robust spheroidal cast iron housings at inlet and outlet ends.
- » Fully automatic for either continuous or intermittent screening of sludges with varying dry solids content.
- » 3 mm to 10 mm diameter screen perforations.
- » Comprehensive Factory Assessment Test of machine and control panel prior to despatch.
- » Reverse function in manual mode to allow the retention cone to be backed off without disconnecting the air supply.
- » Fully compliant, user friendly WIMES 3.04 control panel.
- » Empty weight 1000 kg (standard).
- » Fully compliant, user friendly WIMES 3.04 control panel.
- » Empty weight 1000 kg (standard).



Fig.1 Hydro-Sludge™ Screen - stainless steel option (front) and cast iron with stainless components option (back).

Benefits

Improve downstream process efficiency

Offering a range of screen sizes, the Hydro-Sludge™ Screen reduces loading on downstream processes and improves overall treatment effectiveness. Able to handle a dry solids capacity of up to 9%, the Hydro-Sludge™ Screen removes solids early on in the process, minimising the clogging that would otherwise reduce downstream treatment efficiency.

Cut maintenance costs

With an easy-maintenance standard design, Hydro-Sludge™ Screen has been developed with the operator in mind. The reverse function hatch, inlet access and extended discharge area makes routine inspection, cleaning and maintenance activities quick, simple and safe.

Make savings on your solids handling

Delivering screenings at up to 40% total solids, the Hydro-Sludge™ Screen removes, compacts and dewateres coarse material in sludge to reduce the solids handling burden, cutting the cost of screened solids management, transport and disposal.



Options

The Hydro-Sludge™ Screen is available in two sizes, standard and compact. Whilst both can be used at wastewater treatment plants the compact has proved to be popular for use on cruise liners.

Sludge Dry Solids Content	Standard Unit	Compact Unit
	Throughput (l/s)	Throughput (l/s)
0-1	41	14
2	31	10
3	26	9
4	22	8
5	21	7
6	19	6
7	17	6
8	15	5
9	14	5
Dimensions	670 x 950 x 4300 mm	670 x 1244 x 2710 mm

How it works

1. Flow enters through the centre of a sludge inlet (red arrow).
2. Sludge passes through the perforation and exits via the sludge outlet (blue arrow), whilst the screenings are trapped inside.
3. A rotating screw moves the screenings off the inside of the drum to the pressing zone.
4. In the pressing zone the screenings are pressed against a retention cone which is balanced against the drive load of the screw.
5. Dewatered screenings are discharged by gravity via the screenings outlet (brown arrow).

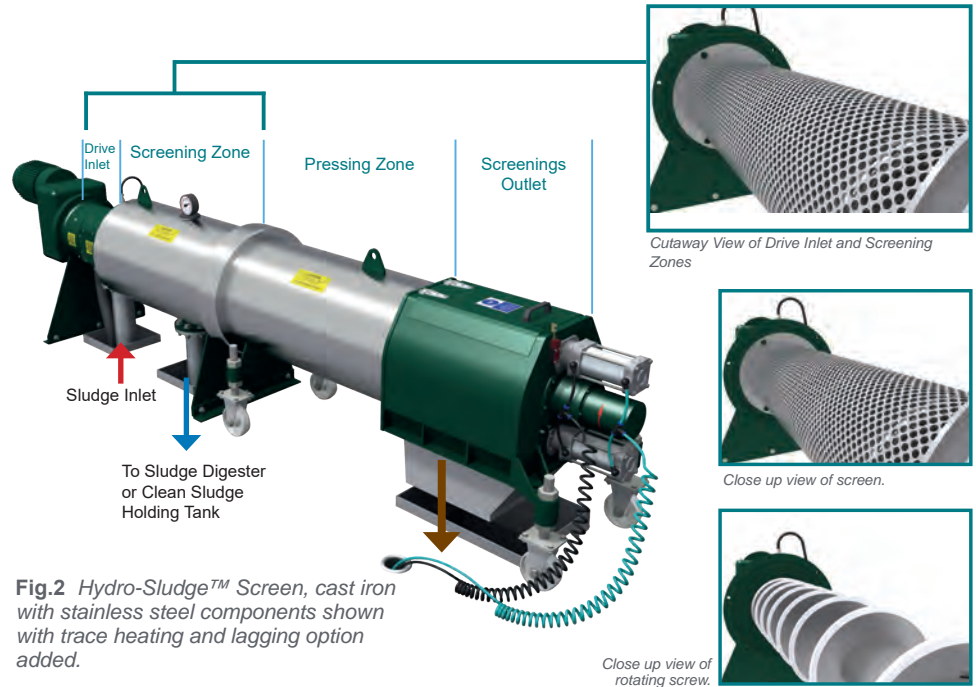

UK Wastewater Services

Hydro International's UK Wastewater Services team is the country's largest provider of screen servicing and maintenance. Operating from five regional offices across the UK they deliver critical support to wastewater treatment plant owners and operators 24 hours a day, 365 days a year.

- » Repair & refurbishment
- » Servicing & maintenance
- » Inlet equipment hire
- » Spares provision
- » Emergency support 24/7

To find out how our services team can help you keep your inlet works working at peak efficiency please call 01305 821142



Hydro International
 Unit 2, Rivermead Court, Kenn Business Park
 Windmill Road, Clevedon, BS21 6FT
 Tel: +44 (0)1275 878371
 Email: wastewatersolutions@hydro-int.com
 Web: hydro-int.com

Patent: www.hydro-int.com/patents

To find out how the Hydro-Sludge™ Screen can help you cut the costs of solids handling and improve downstream treatment efficiency call 01275 878371 or visit:

→ hydro-int.com/hydro-sludge-screen