

# Hydro-Static® Screen

Screen gross solids and floatables at CSO sites with infrequent overflows

## Product Summary

The Hydro-Static® Screen provides economical combined sewer overflow screening at sites with infrequent overflows.

Available in two configurations that provide effective removal of gross solids and floatables, the Hydro-Static® Screen has no moving parts, requires little maintenance and can be supplied in a precast concrete chamber, delivering effective pollution capture for sites with lower flows and operators with smaller budgets.

Though overflows may be infrequent, when they occur they are still damaging to the environment. The Hydro-Static® Screen offers an economically sustainable screen for combined sewer overflow sites with infrequent overflows, but at which environmental protection is still a concern.

## Applications

- » CSO sites with infrequent spills.
- » Floatables control within collection systems.
- » Retrofits or new CSO screening facilities.
- » Storm tank and pumping station overflows.

## Benefits

### Get economical, effective CSO screening

The Hydro-Static® Screen provides effective gross solids and floatables capture and works with small flows and small budgets. Mesh screen panels are coated in a non-stick polymer and corrugated to increase flow-through capacity.

### Minimise maintenance requirements

The Hydro-Static® Screen has no moving parts and requires no power to operate. The patented flow modifying components keep the screen cleaner for longer while the non-stick polymer coating on the screens makes them easier to keep clean.

### Install quickly and easily

The modular design enables swift installation and the ability to retrofit into existing chambers whatever the shape and size.

## Main Features

1. Corrugated mesh screen panels for increased flow-through capacity
2. Non-stick polymer coated mesh screen panels.
3. Patented, flow modifying components provide partial cleansing in the Up-Flow configuration, reducing maintenance costs.

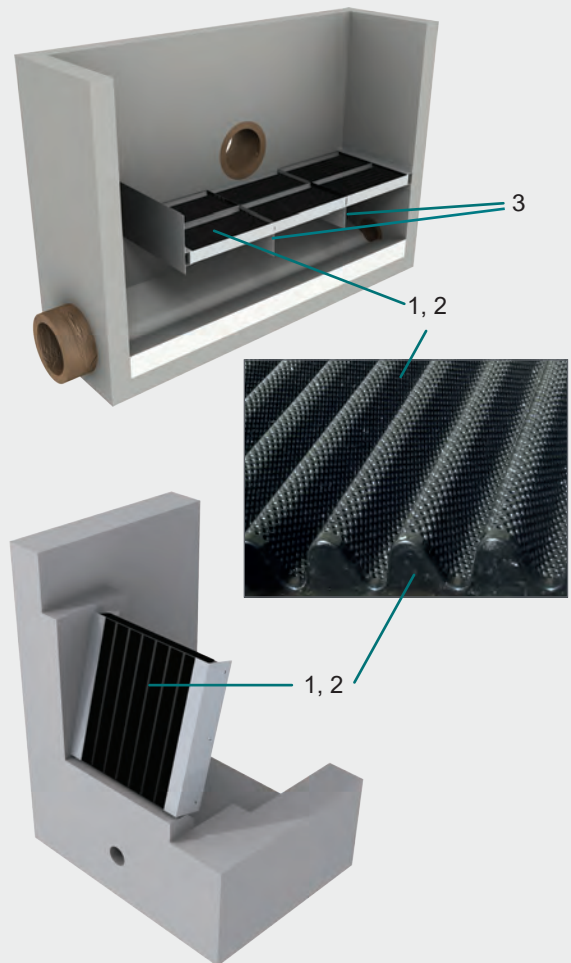

## Performance

- » Recommended design loading range of 50-100 l/s/m<sup>2</sup> (nominal value: 75 l/s/m<sup>2</sup>).
- » Headloss ranges from 40 mm at 50 l/s/m<sup>2</sup> to 100 mm at 100 l/s/m<sup>2</sup>.
- » Screen weight of standard panel (1.215 x 0.641 m) is 20 kg (25.64 kg/m<sup>2</sup> of plan area).

## How it works

- 1) During dry weather conditions the flow to the treatment works will pass underneath the screens in the dry weather flow channel.
- 2) In a storm event the inflow rate to the chamber will exceed the outflow rate causing water levels to rise within the chamber and spill through the screens.
- 3) The Hydro-Static® Screen is mounted over the dry weather flow channel so that the flow passes up and through the screen during a storm event. Solids and floatables are trapped below the screen and returned to the sanitary continuation flow (brown arrow).
- 4) Screened effluent is discharged to a receiving waterway (blue arrow).
- 5) An emergency overflow weir is incorporated into the screen should the peak design flow be exceeded.

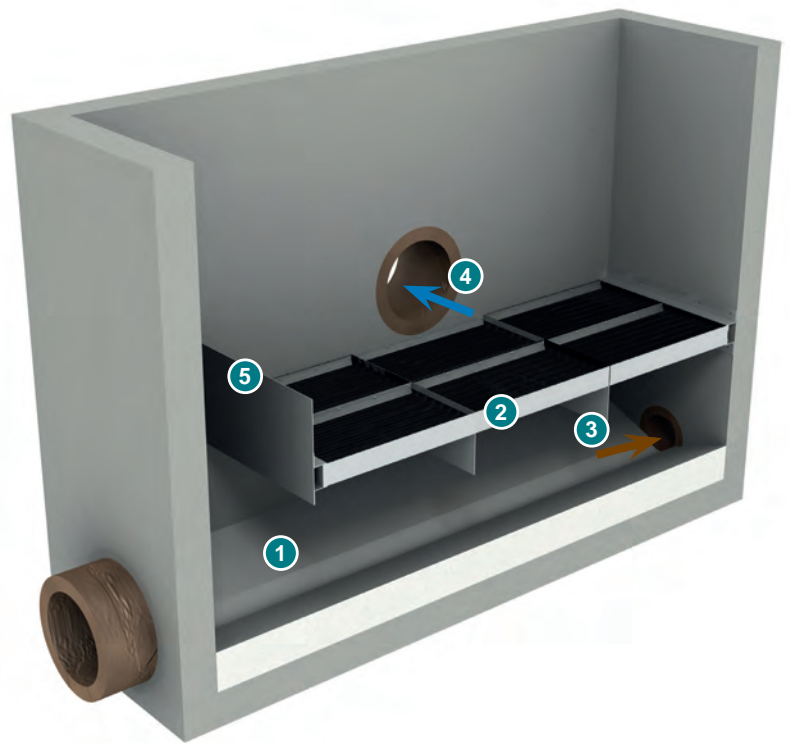

## Make it Smart:

Add Hydro-Logic® Event Duration Monitoring, for data and alerts on the status of your CSO.



📍 Hydro International  
Unit 2, Rivermead Court, Kenn Business Park  
Windmill Road, Clevedon, BS21 6FT  
☎ Tel: +44 (0)1275 878371  
✉ Email: [wastewatersolutions@hydro-int.com](mailto:wastewatersolutions@hydro-int.com)  
🌐 Web: [hydro-int.com](http://hydro-int.com)

Patent: [www.hydro-int.com/patents](http://www.hydro-int.com/patents)

To find out how the Hydro-Static® Screen can economically help you remove solids from CSO discharges and help protect the environment call 01275 878371 or visit:

→ [hydro-int.com/hydro-static-screen](http://hydro-int.com/hydro-static-screen)