

Grit King[®] Compact

Optimized for Plants with Peak Flows up to 2.2 Mgal/d (8.33 MLD)

Product Summary

Advanced Grit Management[®] priced for smaller plants unwilling to sacrifice performance.

Hydro International now offers small wastewater treatment plants an accessible option to deliver 95% removal of all grit entering the plant for peak flows up to 2.4 Mgal/d (9.09 MLD) with 106 micron (µm) performance, or peak flows up to 5 Mgal/d (18.93 MLD) with 212 µm performance.

Advanced Grit Management[®] systems, have often been a luxury item for small plants – until now. Grit King[®] hydrodynamic vortex separation is now available with synthetic internal elements specifically tailored for small plants. The system can be placed in a poured concrete tank and a grout cone is formed in the bottom. The internal components, made of synthetic materials and stainless steel, are installed with inlet and outlet connections. Typically provided with a dry pit or self-priming grit pump, Decanter grit dewatering box, and a control panel to complete this Advanced Grit Management[®] system.

Performance

- » The Grit King[®] Compact can be designed for 95% removal of all grit 106, 150, or 212 µm and larger

How it Works

The Grit King[®] is an advanced hydrodynamic separator that augments gravitational forces to effectively separate grit from water with no moving internal components. Flow is introduced into the Grit King[®] via a tangentially positioned inlet causing a rotational flow path around the dip plate. The flow spirals down the wall of the chamber as solids settle out by gravitational forces and forces created by the rotating flow. The grit collects in the grit sump at the bottom of the unit as the center cone directs flow away from the base, up and around the center shaft into the inside of the dip plate and out the effluent pipe.

The upward flow rotates at a slower velocity than the outer downward flow. The resulting “shear” zone scrubs out the finer particles. The concentrated grit underflow is pumped to a grit dewatering dumpster.

Grit King[®] Compact Layout



Installed Grit King[®] Compact System [right]

Applications

- » New small municipal and industrial wastewater treatment plants
- » Small treatment plant retrofits and upgrades
- » Sediment removal pre-treatment for potable water

Benefits

- » Economical to install, own, and operate
- » A complete Advanced Grit Management[®] system including collection and dewatering
- » No moving parts in the separator, the grit pump is the only mechanical component
- » Compact design with minimal headloss

Grit King[®] Compact Capacity

| Unit Size | 4' (1.2m) | 6' (1.8m) | 8' (2.4 m) | 10' (3.1m) |
|------------------------|--------------------------------|--------------------|---------------------|---------------------|
| Design Cutpoint | Peak Flow, Mgal/d (MLD) | | | |
| 106 µm | ≤ 0.29 (≤ 1.10) | ≤ 0.71 (≤ 2.69) | ≤ 1.33 (≤ 5.04) | ≤ 2.19 (≤ 8.29) |
| 150 µm | ≤ 0.41 (≤ 1.55) | ≤ 1.00 (≤ 3.79) | ≤ 1.88 (≤ 7.12) | ≤ 3.07 (≤ 11.62) |
| 212 µm | ≤ 0.61 (≤ 2.31) | ≤ 1.49 (≤ 5.64) | ≤ 2.81 (≤ 10.64) | ≤ 4.58 (≤ 17.34) |



Design Notes

- » Complete Advanced Grit Management® system, including internal grit separation components, pump, dewatering unit and controls
- » Internal flow structuring components create a long flow path, aiding settlement and maximizing grit capture
- » All-hydraulic design with no moving parts ensures long product life; the grit pump is the only mechanical component in the system

Grit King® Compact Configurations

The synthetic internal components and stainless steel support frame are supplied with this system. A grout cone is formed in the bottom of a concrete tank, components are installed and sealed connections are made to the influent and effluent piping.

The Grit King® Compact is typically supplied with a dry pit or self priming grit pump, controls and a Decanter non-mechanical dewatering bin. Alternative grit dewatering options are available.

Reduce costs with pre-configured components

The Grit King® Compact arrives on-site already configured to fit your tank's dimensions. The system just needs the grout poured for the grit sump. This allows you to rapidly get the system up and running with minimal installation time and costs.



Grit King® Compact with Self-Dumping Decanter Dewatering Option

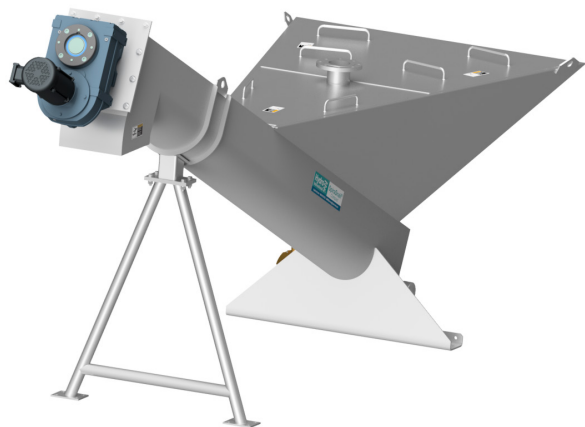

SpiraSnail® Compact Space Efficient Dewatering Classifier Option

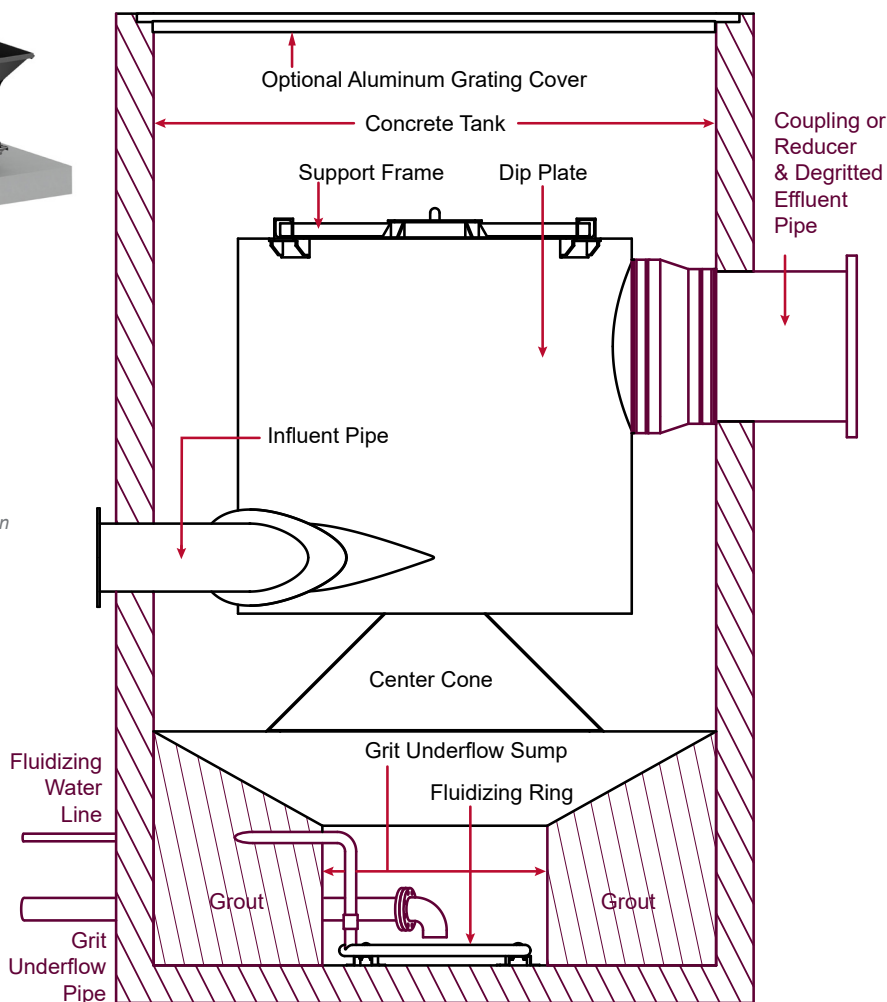

■ Supplied by Hydro ■ Supplied by Others

Grit King® Compact components



📍 Hydro International
2925 NE Alcock Suite 140 | Hillsboro, OR 97124
☎ Tel: (866) 615-8130
✉ Email: questions@hydro-int.com
🌐 Web: www.hydro-int.com

Learn more

Visit our website to learn how the Grit King® Compact system will protect your plant, reduce your operational costs, and improve the performance of your entire plant.

→ hydro-int.com/compact